

IIT-JEE 2010

Physics Paper I

PART III - Physics

SECTION - I

Single Correct Choice Type

This Section contains **8 multiple choice questions**. Each question has four choices (A), (B), (C), and (D) out of which **ONLY ONE is correct**.

57. A thin uniform annular disc (see figure) of mass M has outer radius $4R$ and inner radius $3R$. The work required to take a unit mass from point P on its axis to infinity is:

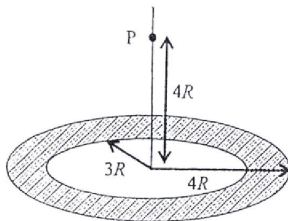

- | | |
|-------------------------------------|--------------------------------------|
| (A) $\frac{2GM}{7R}(4\sqrt{2} - 5)$ | (B) $-\frac{2GM}{7R}(4\sqrt{2} - 5)$ |
| (C) $\frac{GM}{4R}$ | (D) $\frac{2GM}{5R}(\sqrt{2} - 1)$ |

57. (A) Consider an elemental ring of radius r and very small thickness dr .

$$\text{So mass of this element ring} = \frac{M}{\pi(16R^2 - 9R^2)} \times 2\pi r dr = \frac{2Mr}{7R^2} dr$$

Potential due to this ring at a distance $x (= 4R)$ from centre is $dV = -G dm / \sqrt{x^2 + 16R^2}$.

$$\therefore \text{Work} = -V = - \int dV = \frac{2GM}{7R^2} \int_{3R}^{4R} \frac{r}{\sqrt{x^2 + r^2}} dr = \frac{2GM}{7R} (4\sqrt{2} - 5)$$

58. A block of mass m is on an inclined plane of angle θ . The coefficient of friction between the block and the plane is μ and $\tan \theta > \mu$. The block is held stationary by applying a force P parallel to the plane. The direction of force pointing up the plane is taken to be positive. As P is varied from $P_1 = mg(\sin \theta - \mu \cos \theta)$ to $P_2 = mg(\sin \theta + \mu \cos \theta)$, the frictional force f versus P graph will look like.

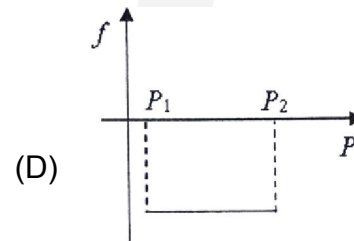
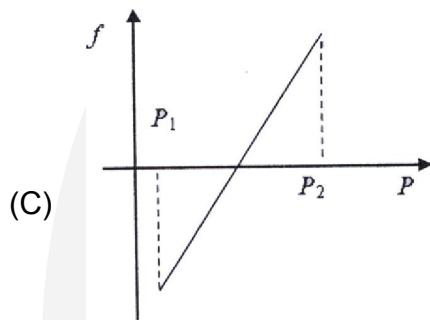
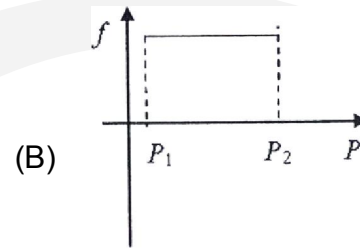
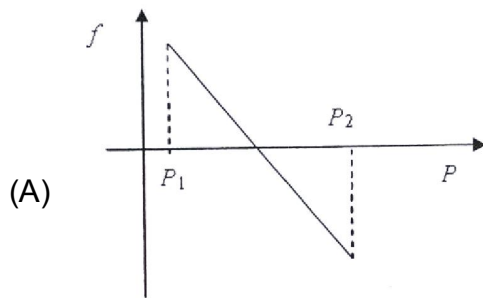
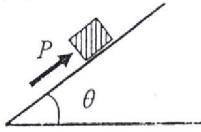

58. (A) $f = mg \sin \theta - P$:
so linear decreasing graph with value ranging from $\mu mg \cos \theta$ to $-\mu mg \cos \theta$.
59. A real gas behaves like an ideal gas if its
- (A) pressure and temperature are both high
 (B) pressure and temperature are both low
 (C) pressure is high and temperature is low
 (D) pressure is low and temperature is high
59. (D) Pressure is low and temperature is high as pressure decreases & temperature increases the volume of gas increases & volume of gas molecules becomes negligible & can be neglected.

60. Consider a thin square sheet of side L and thickness t , made of a material of resistivity ρ . The resistance between two opposite faces, shown by the shaded areas in the figure is:

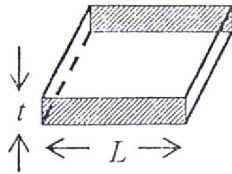

- (A) directly proportional to L (B) directly proportional to t
 (C) independent of L (D) independent of t
60. (C) $R = \rho L / A$
 So, $R \propto (L / A) \Rightarrow R \propto \{L / (t \times L)\} \Rightarrow R \propto (1 / t)$
61. Incandescent bulbs are designed by keeping in mind that the resistance of their filament increases with the increase in temperature. If at room temperature, 100 W, 60 W and 40 W bulbs have filament resistance R_{100} , R_{60} and R_{40} , respectively, the relation between these resistances is:

- (A) $\frac{1}{R_{100}} = \frac{1}{R_{40}} + \frac{1}{R_{60}}$ (B) $R_{100} = R_{40} + R_{60}$
 (C) $R_{100} > R_{60} > R_{40}$ (D) $\frac{1}{R_{100}} > \frac{1}{R_{60}} > \frac{1}{R_{40}}$

61. (D) $P = V^2 / R$ so $\frac{1}{R_{100}} > \frac{1}{R_{60}} > \frac{1}{R_{40}}$.

Also, $\frac{1}{R_{100}} = \frac{1}{R_{40}} + \frac{1}{R_{60}}$ at high temperature (which bulb reaches on glowing)
 but not at room temperature.

62. To verify Ohm's law, a student is provided with a test resistor R_T , a high resistance R_1 , a small resistance R_2 , two identical galvanometers G_1 and G_2 , and a variable voltage source V . The correct circuit to carry out the experiment is:

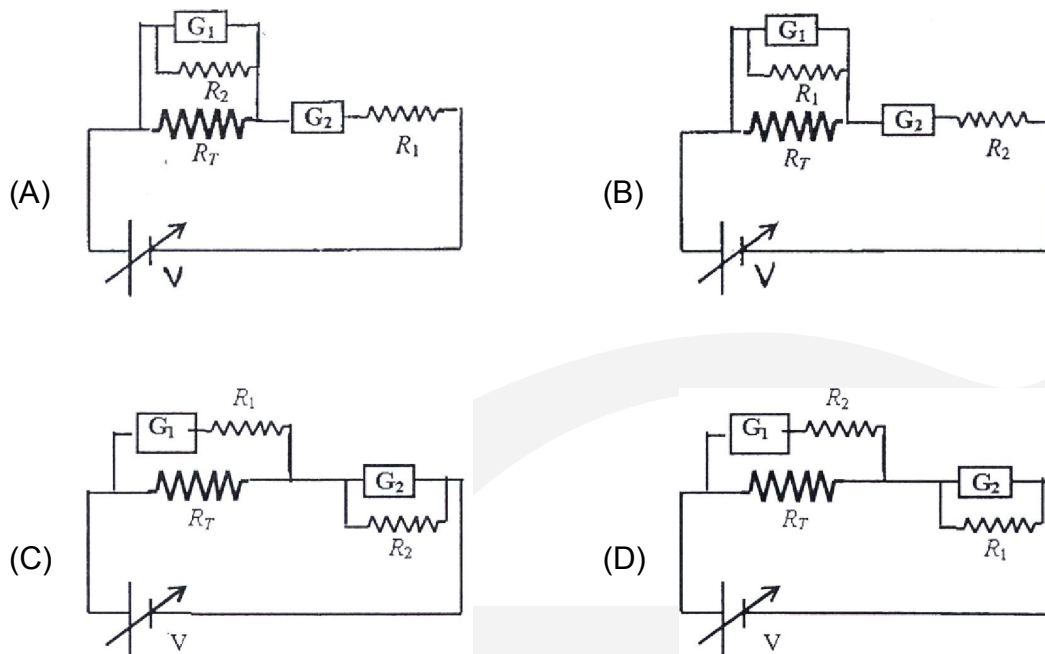

62. (C) Voltmeter is constructed by adding high resistance in series with galvanometer and connected in parallel to test resistance.
Ammeter is formed by adding a low resistance in parallel with galvanometer and connected in series with test resistance.

63. A thin flexible wire of length L is connected to two adjacent fixed points and carries a current I in the clockwise direction, as shown in the figure. When the system is put in a uniform magnetic field of strength B going into the plane of the paper, the wire takes the shape of a circle. The tension in the wire is

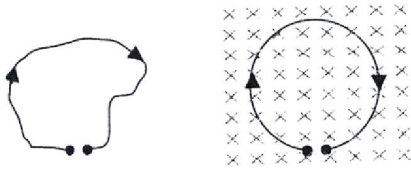

- (A) IBL (B) IBL / π (C) $IBL / 2\pi$ (D) $IBL / 4\pi$

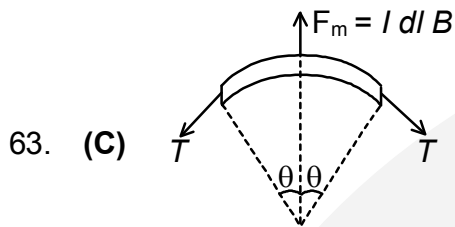

Consider an element of length dl .
 For equilibrium, $2T \sin \theta = I dl B$.
 Since θ is very small, $T(2\theta) = I dl B$.
 $T (dl / L) \times 2\pi = I dl B$
 $\Rightarrow T = I B L / 2\pi$

64. An AC voltage source of variable angular frequency ω and fixed amplitude V_0 is connected in series with a capacitance C and an electric bulb of resistance R (inductance zero). When ω is increased.
- (A) the bulb glows dimmer
 (B) the bulb glows brighter
 (C) total impedance of the circuit is unchanged
 (D) total impedance of the circuit increase

64. (B) $Z = \sqrt{X_L^2 + R^2}$

$$P = I_0 V_0 \cos \phi = \frac{V_0^2 R}{Z^2}$$

$$Z = \sqrt{\frac{1}{(\omega C)^2} + R^2} \text{ as } \omega \text{ increase } Z \text{ decreases and power increases.}$$

So bulb glows brighter.

SECTION - II
Multiple Correct Choice Type

This Section contains **5 multiple choice questions**. Each question has four choice (A), (B), (C) and (D) out of which **ONE OR MORE** may be correct.

65. A student uses a simple pendulum of exactly 1 m length to determine g , the acceleration due to gravity. He uses a stop watch with the least count of 1 sec for this and records 40 seconds for 20 oscillations. For this observation, which of the following statement(s) is (are) true?
 (A) Error ΔT in measuring T , the time period, is 0.05 seconds
 (B) Error ΔT in measuring T , the time period, is 1 second
 (C) Percentage error in the determination of g is 5%
 (D) Percentage error in the determination of g is 2.5%

65. **(AC)** Error in $T = 1 / 20$ sec = 0.05 sec &
 % error in $g = 2 \times (\Delta T / T) \times 100\% = 2 \times (0.05 / 2) \times 100\% = 5\%$

66. A few electric field lines for a system of two charges Q_1 and Q_2 fixed at two different points on the x -axis are shown in the figure. These lines suggest that

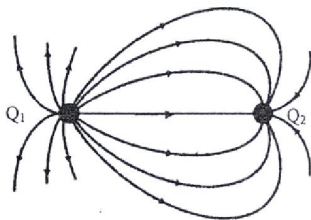

- (A) $|Q_1| > |Q_2|$ (B) $|Q_1| < |Q_2|$
 (C) at a finite distance to the left of Q_1 the electric field is zero
 (D) at a finite distance to the right of Q_2 the electric field is zero

66. **(AD)** Closer Electric field lines \Rightarrow More electric field
 $\Rightarrow |Q_1| > |Q_2| \Rightarrow$ As (A) is correct.

Due to point charge $|\vec{E}| \propto 1 / d^2$, since $|Q_1| > |Q_2|$

\Rightarrow Point where field is zero must be right of $Q_2 \Rightarrow$ (D) is correct.

67. One mole of an ideal gas in initial state A undergoes a cyclic process ABCA, as shown in the figure. Its pressure at A is P_0 . Choose the correct option(s) from the following

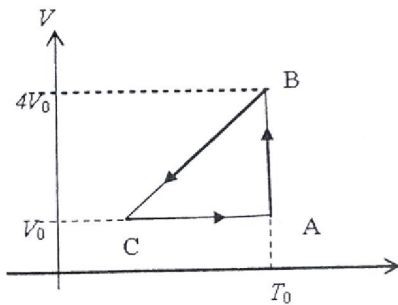

- (A) Internal energies at A and B are the same
 (B) Work done by the gas in process AB is $P_0 V_0 \ln 4$
 (C) Pressure at C is $P_0 / 4$
 (D) Temperature at C is $T_0 / 4$
67. **(AB)** Since $T_A = T_B \Rightarrow U_A = U_B \Rightarrow$ (A) is correct.
 AB is isothermal Expansion $\Rightarrow W_{AB} = P_0 V_0 \ln 4 \Rightarrow$ (B) is correct.
 Since it is not specified that BC does not pass through origin,
 so conclusion possible about state at C.
68. A point mass of 1 kg collides elastically with a stationary point mass of 5 kg. After their collision, the 1 kg mass reverses its direction and moves with a speed of 2 ms^{-1} . Which of the following statement(s) is (are) correct for the system of these two masses?
 (A) Total momentum of the system is 3 kg ms^{-1}
 (B) Momentum of 5 kg mass after collision is 4 kg ms^{-1}
 (C) Kinetic energy of the centre of mass is 0.75 J
 (D) Total kinetic energy of the system is 4 J

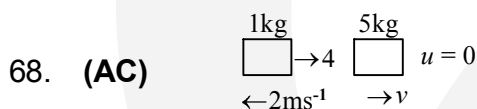

$$\text{CLM} \rightarrow u = -2 + 5v \Rightarrow 5v - u = 2 \dots\dots(1)$$

$$\text{Coefficient of Restitution : } u = 2 + v \Rightarrow u - v = 2 \dots\dots(2)$$

$$\text{for (1) and (2) } v = 1 \text{ ms}^{-1}, u = 3 \text{ ms}^{-1}$$

$$\therefore \text{ Total Momentum of the System is } 3 \text{ kg ms}^{-1} \Rightarrow \text{(A) is correct}$$

$$\text{Momentum of 5 kg after collision} = 5 \times 1 = 5 \text{ kg ms}^{-1} \Rightarrow \text{(B) is incorrect}$$

$$V_{cm} = \{(-1 \times 2) + (5 \times 1) / 6\} = 1/2 \text{ ms}^{-1}$$

$$\therefore \text{ K.E of c.m.} = \{(1/2) \times (6) (1/2)^2\} = 6/8 = 3/4 = 0.75 \text{ J} \quad \therefore \text{(C) is correct}$$

$$\text{Total K. E. of the system} = 4.5 \text{ J} \Rightarrow \text{(D) is incorrect}$$

69. A ray OP of monochromatic light is incident on the face AB of prism $ABCD$ near vertex B at an incident angle of 60° (see figure). If the refractive index of the material of the prism is $\sqrt{3}$, which of the following is (are) correct?

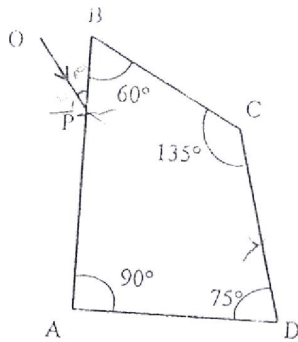

- (A) The ray gets totally internally reflected at face CD
 (B) The ray comes out through face AD
 (C) The angle between the incident ray and the emergent ray is 90°
 (D) The angle between the incident ray and the emergent ray is 120°
69. **(ABC)** Angle of incidence at CD is greater than critical angle on $CD \Rightarrow$ (A) is correct. Path followed by ray and various angles are as indicated in the diagram.

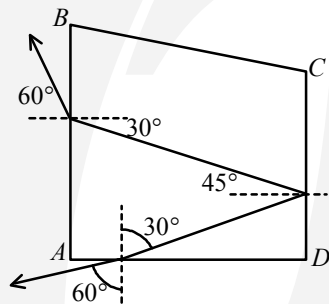

Since ray emerges at 60° to face AD , it is at 90° to incident ray.

SECTION - III
Linked Comprehension Type

This Section contains **2 paragraphs**. Based upon the first paragraph **2 multiple choice questions** and based upon the second paragraph **3 multiple choice questions** have to be answered. Each of these questions has four choices (A), (B), (C) and (D) out of which **only one** is correct.

Paragraph for Q.No. 70 to Q.No. 71

Electrical resistance of certain materials, known as superconductors, changes abruptly from a nonzero value to zero as their temperature is lowered below a critical temperature $T_C(0)$. An interesting property of superconductors is that their critical temperature becomes smaller than $T_C(0)$ if they are placed in a magnetic field, i.e., the critical temperature $T_C(B)$ is a function of the magnetic field strength B . The dependence of $T_C(B)$ on B is shown in the figure.

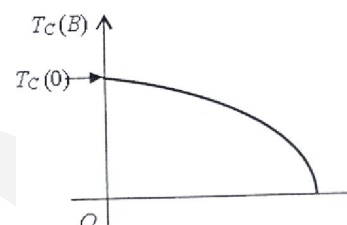

70. In the graphs below, the resistance R of a superconductor is shown as a function of its temperature T for two different magnetic fields B_1 (solid line) and B_2 (dashed line). If B_2 is larger than B_1 , which of the following graphs shows the correct variation of R with T in these fields?

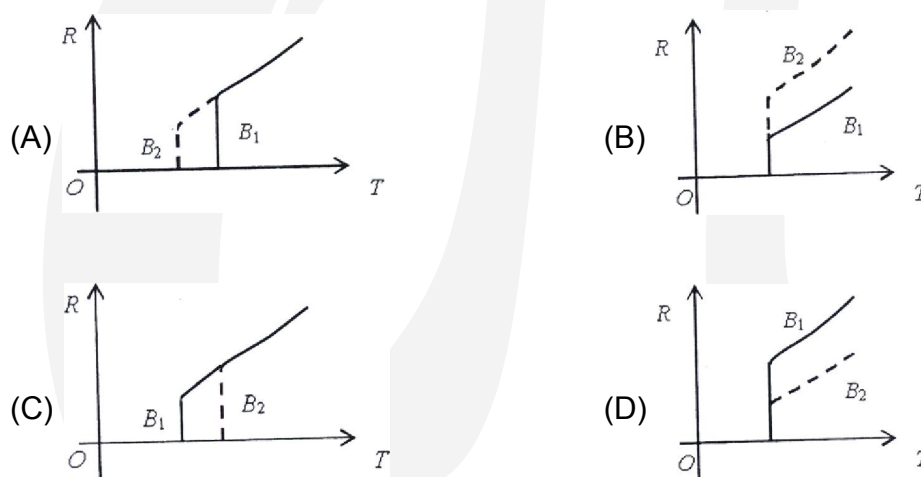

70. (A) T_{B_2} should be less than T_{B_1} and above critical temperature, resistance independent of B : identical graph.
71. A superconductor has $T_C(0) = 100$ K. When a magnetic field of 7.5 Tesla is applied its T_C decreases to 75 K. For this material one can definitely say that when
- (A) $B = 5$ Tesla, $T_C(B) = 80$ K (B) $B = 5$ Tesla, $75 \text{ K} < T_C(B) < 100$
- (C) $B = 10$ Tesla, $75 \text{ K} < T_C(B) < 100$ K (D) $B = 10$ Tesla, $T_C(B) = 70$ K
71. (B) For $B = 5$ Tesla, $T_C(B)$ should lying between 75 K to 100 K &
For $B = 10$ Tesla, $T_C(B)$ should be less than 75 K

Paragraph for Q.NO 72 to Q.NO. 74

When a particle of mass m moves on the x -axis in a potential of the form $V(x) = kx^2$, it performs simple harmonic motion. The corresponding time period is proportional to $\sqrt{\frac{m}{k}}$, as can be seen easily using dimensional analysis. However, the motion of a particle can be periodic even when its potential energy increases on both sides of $x = 0$ in a way different from kx^2 and its total energy is such that the particle does not escape to infinity. Consider a particle of mass m moving on the x -axis. Its potential energy is $V(x) = \alpha x^4$ ($\alpha > 0$) for $|x|$ near the origin and becomes a constant equal to V_0 for $|x| \geq X_0$ (see figure).

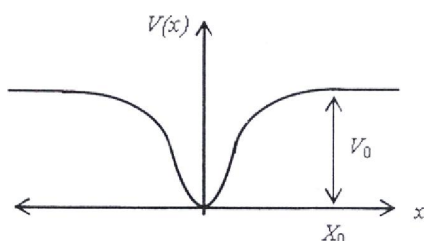

72. If the total energy of the particle is E , it will perform periodic motion only if
 (A) $E < 0$ (B) $E > 0$ (C) $V_0 > E > 0$ (D) $E > V_0$
72. **(C)** Total energy should be less than V_0 for periodic motion.
73. For periodic motion of small amplitude A , the time period T of this particle is proportional to
 (A) $A\sqrt{\frac{m}{\alpha}}$ (B) $\frac{1}{A}\sqrt{\frac{m}{\alpha}}$ (C) $A\sqrt{\frac{\alpha}{m}}$ (D) $\frac{1}{A}\sqrt{\frac{\alpha}{m}}$
73. **(B)** By dimensional analysis, $\alpha A^2 \equiv k$. $\therefore T \propto \frac{1}{A}\sqrt{\frac{m}{\alpha}}$
74. The acceleration of this particle for $|x| > X_0$ is
 (A) proportional to V_0 (B) proportional to $\frac{V_0}{mX_0}$
 (C) proportional to $\sqrt{\frac{V_0}{mX_0}}$ (D) zero
74. **(D)** Since, for $|x| > x_0$, $F = \frac{-dV}{dx} = 0$

SECTION - IV (Integer Type)

This Section contains **TEN** questions. The answer to each question is a **single-digit integer**, ranging from 0 to 9. The correct digit below the question number in the ORS is to be bubbled.

75. A stationary source is emitting sound at a fixed frequency f_0 , which is reflected by two cars approaching the source. The difference between the frequencies of sound reflected from the cars is 1.2 % of f_0 . What is the difference in the speed of the cars (in km per hour) to the nearest integer? The cars are moving at constant speeds much smaller than the speed of sound which is 330 ms^{-1} .

$$75. \quad [7] \quad f_A = f_0 \left(\frac{c+V_A}{c} \right) \cdot \left(\frac{c}{c-V_A} \right) \quad \text{and,} \quad f_B = f_0 \left(\frac{c+V_B}{c} \right) \cdot \left(\frac{c}{c-V_B} \right)$$

$$\therefore \frac{f_A - f_B}{f_0} = \frac{c+V_A}{c-V_A} - \frac{c+V_B}{c-V_B}$$

$$\text{On solving, } \frac{1.2}{100} = \frac{2c(V_A - V_B)}{c^2} \Rightarrow V_A - V_B = \frac{198}{100} = \frac{198}{100} \times \frac{18}{5} = 7.128 \approx 7 \text{ Kmph.}$$

76. The focal length of a thin biconvex lens is 20 cm. When an object is moved from a distance of 25 cm in front of it to 50 cm, the magnification of its image changes from m_{25} to m_{50} .

The ratio $\frac{m_{25}}{m_{50}}$ is

$$76. \quad [6] \quad \text{Image position when } u = 25 \text{ cm; } v_{25} = \frac{uf}{u-f} = 100 \text{ cm}$$

$$\text{Image position when } u = 50 \text{ cm; } v_{50} = \frac{uf}{u-f} = \frac{100}{3} \text{ cm}$$

$$m_{25} = \frac{v_{25}}{u} = \frac{100}{25} = 4 \quad \text{and,} \quad m_{50} = \frac{v_{50}}{u} = \frac{100}{3 \times 50} = \frac{2}{3}$$

$$\therefore \text{Ratio } \frac{m_{25}}{m_{50}} = \frac{4 \times 3}{2} = 6$$

77. An α -particle and a proton are accelerated from rest by a potential difference of 100 V. After this, their de Broglie wavelengths are λ_α and λ_p respectively. The ratio $\frac{\lambda_p}{\lambda_\alpha}$, to the nearest integer, is

$$77. \quad [3] \quad Vq = E \quad \text{and} \quad \lambda = \frac{h}{\sqrt{2mE}}$$

$$\therefore \frac{\lambda_p}{\lambda_\alpha} = \sqrt{\frac{m_\alpha \cdot E_\alpha}{m_p E_p}} = \sqrt{\frac{4 \times 2E}{E}} = 2\sqrt{2} \approx 3$$

78. When two identical batteries of internal resistance 1Ω each are connected in series across a resistor R , the rate of heat produced in R is J_1 . When the same batteries are connected in parallel across R , the rate is J_2 . If $J_1 = 2.25 J_2$ then the value of R in Ω is

$$78. \quad [4] \quad J_1 = \left(\frac{2E}{R+2} \right)^2 R \quad J_2 = \left(\frac{E}{R+\frac{1}{2}} \right)^2 R \quad \text{and } J_1 = 2.25 J_2$$

$$\Rightarrow \frac{(2E)^2}{(R+2)^2} \cdot R = \frac{225}{100} \cdot \frac{(2E)^2}{(2R+1)^2} \cdot R \quad \therefore \text{on solving } R = 4 \Omega$$

79. Two spherical bodies A (radius 6 cm) and B (radius 18 cm) are at temperatures T_1 and T_2 , respectively. The maximum intensity in the emission spectrum of A is at 500 nm and in that B is at 1500 nm. Considering them to be black bodies, what will be the ratio of the rate of total energy radiated by A to that of B ?

79. [9] From Wein's displacement law $\lambda T = \text{constant} \quad \therefore T_1 : T_2 = 3 : 1$
rate of energy radiated, $E = \sigma \epsilon A T^4 = \sigma \epsilon 4 \pi r^2 T^4$

$$\text{i.e. } E \propto r^2 T^4 \Rightarrow \frac{E_A}{E_B} = \frac{(6)^2}{(18)^2} \cdot \left(\frac{3}{1} \right)^4 = 9$$

80. When two progressive waves $y_1 = 4 \sin(2x - 6t)$ and $y_2 = 3 \sin\left(2x - 6t - \frac{\pi}{2}\right)$ are superimposed, the amplitude of the resultant wave is

80. (5) Since $\Delta\phi = \pi/2$, $A_{\text{resultant}} = \sqrt{A_1^2 + A_2^2 + 2A_1A_2 \cos \Delta\phi} = \sqrt{(4)^2 + (3)^2} = 5$

81. A 0.1 kg mass is suspended from a wire of negligible mass. The length of the wire is 1 m and its cross-sectional area is $4.9 \times 10^{-7} \text{ m}^2$. If the mass is pulled a little in the vertically downward direction and released, it performs simple harmonic motion of angular frequency 140 rad s^{-1} . If the Young's modulus of the material of the wire is $n \times 10^9 \text{ Nm}^{-2}$, the value of n is

81. [4] $K \times \text{elongation} = mg \Rightarrow K \cdot \frac{mgl}{AY} = mg \Rightarrow K = \frac{AY}{l}$

$$\omega = \sqrt{\frac{AY}{ml}} = 140 \Rightarrow n = 4$$

82. A binary star consists of two stars A (mass $2.2 M_s$) and B (mass $11 M_s$), where M_s is the mass of the sun. They are separated by distance d and are rotating about their centre of mass, which is stationary. The ratio of the total angular momentum of the binary star to the angular momentum of star B about the centre of mass is.

82. [6] distance of COM w.r.t. A = $\left(\frac{11 M_s}{11 M_s + 2.2 M_s} \right) \times d = \frac{5d}{6}$

$$L_A = 2.2 M_s \omega (5d/6)^2$$

$$L_B = 11 M_s \omega (d/6)^2 \quad \text{and} \quad L_{total} = L_A + L_B = \frac{11}{6} M_s \omega d^2$$

$$\therefore \frac{L_{total}}{L_B} = \frac{\frac{11}{6} M_s \omega d^2}{11 M_s \omega (d/6)^2} = 6$$

83. Gravitational acceleration on the surface of a planet is $\frac{\sqrt{6}}{11} g$, where g is the gravitational acceleration on the surface of the earth. The average mass density of the planet is $\frac{2}{3}$ times that of the earth. If the escape speed on the surface of the earth is taken to be 11 kms^{-1} , the escape speed on the surface of the planet in kms^{-1} will be.

83. [3] $\rho_{planet} = \frac{2}{3} \rho_{earth}$

$$\therefore \frac{\frac{3}{4} \pi R_{planet}^3}{\frac{4}{3} \pi R_{earth}^3} = \frac{2}{3} \frac{M_{earth}}{M_{planet}}$$

Also, $\frac{GM_{planet}}{R_{planet}^2} = \frac{\sqrt{6}}{11} \frac{GM_{earth}}{R_{earth}^2}$

$$\frac{R_{planet}}{R_{earth}} = \frac{3\sqrt{6}}{22} \quad \text{and} \quad \frac{M_{planet}}{M_{earth}} = \frac{54\sqrt{6}}{11 \times (22)^2}$$

$$v_{planet} = \sqrt{\frac{2GM_{planet}}{R_{planet}}} = 3$$

84. A piece of ice (heat capacity = $2100 \text{ J kg}^{-1} \text{ }^\circ\text{C}^{-1}$ and latent heat = $3.36 \times 10^5 \text{ J kg}^{-1}$) of mass m grams is at -5°C at atmospheric pressure. It is given 420 J of heat so that the ice starts melting. Finally when the ice-water mixture is in equilibrium, it is found that 1 gm of ice has melted. Assuming there is no other heat exchange in the process, the value of m is.

84. **[8]** $m \times 2100 \times 10^{-3} \times 5 + 1 \times 10^{-3} \times 3.36 \times 10^5 = 420$
 $\Rightarrow 10.5 m + 336 = 420$
 $\Rightarrow m = 840 / 10.5 = 8 \text{ gm}$